



# SANY

Quality Changes the World



## **HYDRAULIC CRAWLER CRANE** **SCC 750E**

# HYDRAULIC CRAWLER CRANE

## CONTENT

### P3

#### SCC750E Crawler Crane

Outline Dimensions  
Main Technical Features  
Performance Data  
Transport Dimensions  
Hoisting Diagram

### P11

#### Specifications

Upperworks  
Lowerworks  
Operation Device  
Safety Devices

### P18

#### Operating Condition Combination

Operating Condition Combination  
H Operating Condition of Boom  
FJ Operating Condition of Fixed Jib

# SCC750E

04	Outline Dimension
05	Main Technical Features
06	Performance Data
07	Transport Dimensions
10	Hoisting Diagram

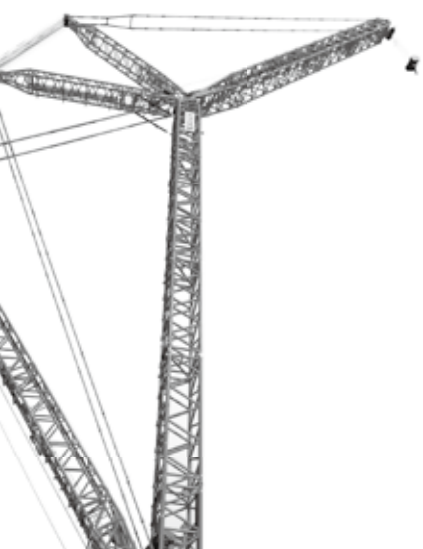

## OUTLINE DIMENSIONS

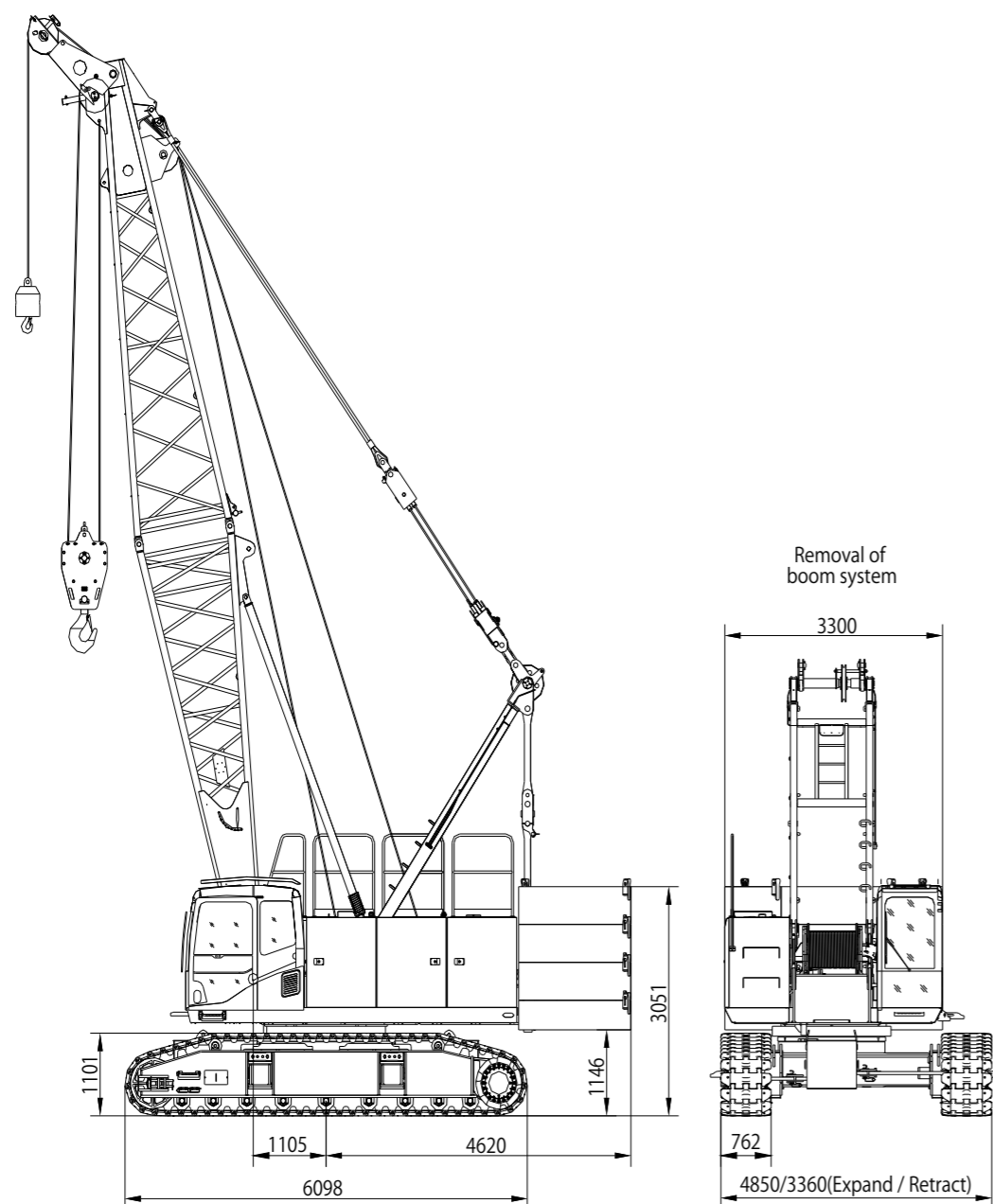

## TECHNICAL FEATURES

### 1. Highly Secured Control System:

There are two operation modes, working and assembly for your convenience. It features with electronic level gauge, machine-leaving stop action, and emergency electrical control, with complete set of safety and monitoring device. Load moment limiter is free of calibration, providing higher safety of the equipment, and less auxiliary operating time; slewing area limit device is optional, to improve the safety of the equipment;

### 2. Excellent Operating Performance:

Maximum load regulation and electronic-over-hydraulic controls ensure smooth micro-movement and stable operation. A real-time queried electronic load chart is provided, more conveniently and quickly;

### 3. Reliable Function Assurance:

The safety margin in structural design is sufficient; load sensitive control hydraulic system is adopted. Hydraulic technology of world-renowned brands, and high-quality key parts, such as pumps, valves, motors, and reducers, are also adopted to ensure system stability and reliability. The control system is fully capable to function stably in extreme weather, such as high-and-cold, high-temperature, and high plateau weather; sensor has a protection against lightning strike; the entire machine adopts the closed wiring way, with waterproof / dust-proof protective grade up to IP65 and with longer life applied;

### 4. Convenient Maintenance Access:

It takes no more than 10min/person to adjust, no more than 30min/person for daily maintenance and no more than 2h/person to repair the machine. The complete set of fault self-diagnosis and inquiry system is configured, thus reducing the equipment handling time; GPS remote monitoring system is optional for easy maintenance and management.

### 5. Powerful lifting capacity:

Large chassis design ensures excellent machine performance and stability within 360° rotation. The max. lifting capacity of boom is 71t x 4m=284t·m, the max. lifting capacity of jib is 6.7t x 22m=147t·m. The rope diameter of main and auxiliary hoisting devices are 20mm and the rated single rope pull of main and auxiliary winch is 7t.

### 6. High-efficient operating speed:

Outmost layer line speed of main and auxiliary lifting winches is 120m/min, and of luffing winch is 100m/min;

### 7. Flexible Configuration Combination:

Free fall winch is optional for main and auxiliary lifting winches.

### 8. Optimized Transportation Programs:

With telescopic crawler, the maximum transportation width of whole machine is 3.36m, ensuring it to be transported around freely.

## PERFORMANCE PARAMETERS

Main technical parameters of SCC750E crawler crane			
Performance Index		Unit	Parameter
Standard Boom Operating Condition	Max. Rated Lifting Capacity	t	75
	Max. Lifting Torque	m	71t×4m
	Length of Basic Boom	m	12
	Longest Boom	m	57
Fixed Jib Operating Condition	Boom Luffing Angle	°	30° ~80°
	Max. Rated Lifting capacity	t	7
Fixed Jib Operating Condition	Max. Rated Lifting Torque	m	6.7t×22m
	Boom Length	m	27~42
	Jib Length	m	9~18
	Longest boom + Longest luffing jib	m	42+18
Speed parameters	Rope Speed of Main and Auxiliary Winches	m/min	0~120(third layer)
	Rated single lifting rope pull	t	7
	Rope Speed of Luffing Winch*	m/min	0~100(Forth layer)
	Slewing Speed	rpm	0~3
	Traveling Speed*	Km/h	0~1.2
Engine	Gradient capability	%	30
	Model		6CTAA8.3-C240
	Output power	kW	179
Transportation Parameter	Rated speed	rpm	2200
	Overall weight (Basic boom + 75t hook)	t	63
	Weight of counterweight	t	24
	Max. Transportation Weight of Single Piece (including boom base, but not including central and rear counterweights)	t	34.3
	Transportation Dimension mm (L×W×H) (including boom base, but not including central and rear counterweights)	mm	12300×3360×3300
	Average Ground Pressure	MPa	0.09

Notes: Rope speed of main / auxiliary winch, rope speed of luffing winch, slewing and traveling speeds will change with the load;

## TRANSPORTATION DIMENSIONS

<b>Body (not including boom base, and central and rear counterweights)</b>	×1
Length (L)	8.2m
Width (B)	3.36m
Height(H)	3.3m
Weight	32.8t
<b>Body (not including central and rear counterweights)</b>	×1
Length (L)	12.3m
Width (B)	3.36m
Height(H)	3.3m
Weight	34.3t
<b>Track frame assemblies</b>	×2
Length (L)	6.10m
Width (B)	1.12m
Height(H)	1.11m
Weight	6.90t
<b>Counterweight tray</b>	×1
Length (L)	3.324m
Width (B)	1.67m
Height (H)	0.66m
Weight	6.0t
<b>Rear counterweight welded parts</b>	×3
Length (L)	3.324m
Width (B)	1.67m
Height(H)	0.62m
Weight	6.0t
<b>Central counterweight blocks</b>	×2
Length (L)	1.33m
Width (B)	0.78m
Height(H)	0.79m
Weight	1.5t
<b>Boom base</b>	×1
Length (L)	6.22m
Width (B)	1.53m
Height(H)	1.79m
Weight	1.49t

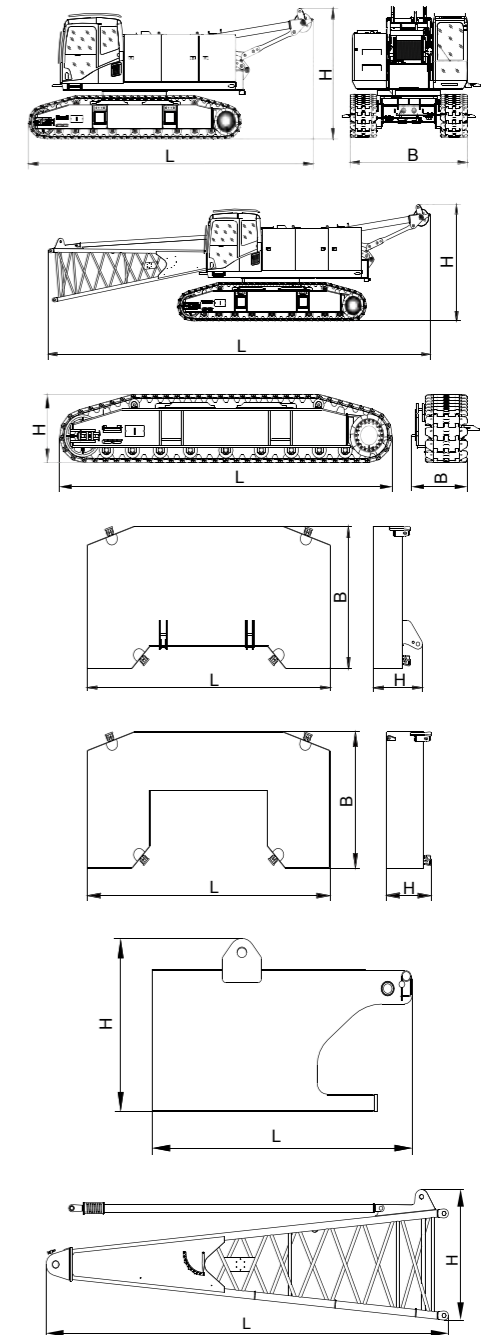

## TRANSPORTATION DIMENSIONS

<b>Boom jib</b>	×1
Length (L)	6.47m
Width (B)	1.79m
Height(H)	1.67m
Weight	1.1t
<b>3m boom insert</b>	×1
Length (L)	3.14m
Width (B)	1.53m
Height(H)	1.69m
Weight	0.46t
<b>6m boom insert</b>	×1
Length (L)	6.14m
Width (B)	1.53m
Height(H)	1.69m
Weight	0.77t
<b>9m boom insert</b>	×4
Length (L)	9.14m
Width (B)	1.53m
Height(H)	1.69m
Weight	0.93t
<b>Jib tip</b>	×1
Length (L)	4.94m
Width (B)	0.87m
Height(H)	0.93m
Weight	0.36t
<b>Jib base</b>	×1
Length (L)	4.69m
Width (B)	0.89m
Height(H)	0.77m
Weight	0.3t
<b>4.5m jib inserts</b>	×2
Length (L)	4.57m
Width (B)	0.87m
Height(H)	0.958m
Weight	0.2t

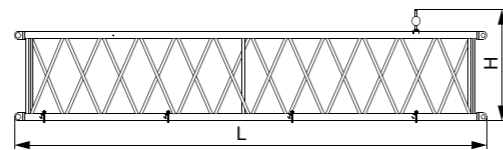
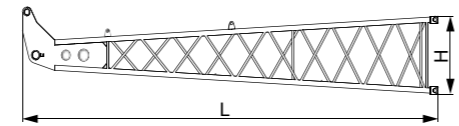
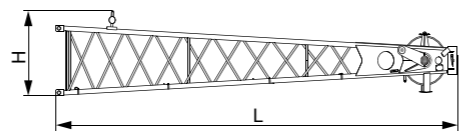
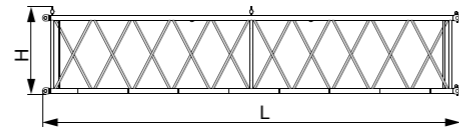
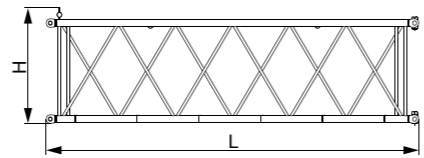
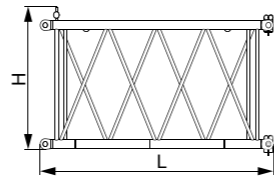
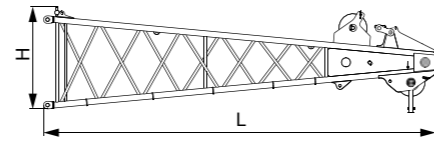

## TRANSPORTATION DIMENSIONS

<b>Boom extension</b>	×1
Length (L)	1.47m
Width (B)	0.93m
Height (H)	0.61m
Weight	0.24t
<b>75t lifting hook</b>	×1
Length (L)	1.75m
Width (B)	0.69m
Height (H)	0.46m
Weight	0.70t
<b>45t lifting hook</b>	×1
Length (L)	1.52m
Width (B)	0.69m
Height (H)	0.37m
Weight	0.49t
<b>15 hook</b>	×1
Length (L)	1.34m
Width (B)	0.60m
Height (H)	0.35m
Weight	0.28t
<b>9t ball hook</b>	×1
Length (L)	0.75m
Width (B)	0.37m
Height(H)	0.37m
Weight	0.25t

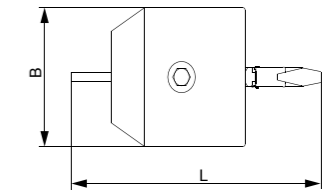
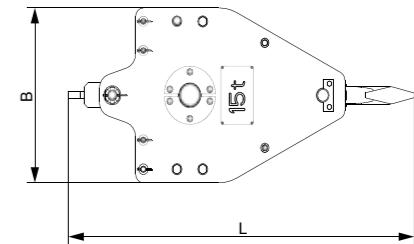
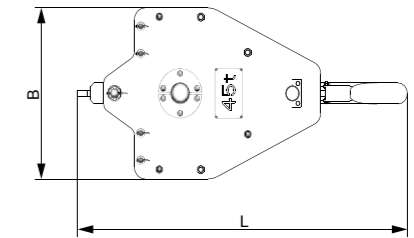
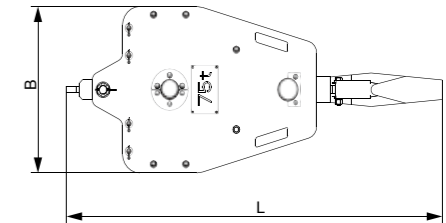
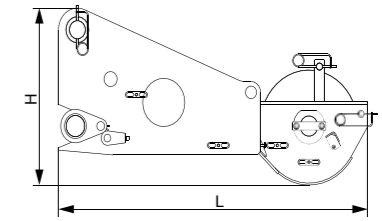

## Notes:

1. The transportation dimensions are not drawn to proportion. The dimensions in the sketch are design value excluding packages.
2. The weight is design value and there may be tiny difference due to the manufacturing calibration.
3. After product upgrading, the actual weight is subjected to the latest products.

# SCC750E

Operating Condition Combination	19
H Operating Condition	20
FJ Operating Condition of Fixed Jib	25

## SPECIFICATION / SUPERSTRUCTURE

### 1) Engine

- Inline six-cylinder water-cooled turbo 6CTAA8.3-C240 engine is adopted as standard configuration.
- Rate Power/Speed: 179kW/2200rpm;
- Emission Standard: TierII
- Air Filter: Two-stage filtering system composed of air pre-filter and air filter.
- Fuel Tank Volume: 400L

### 2) Electrical Control System

- The CAN bus technology is applied for data communication between integrated moment intelligent control system and data recorder, and for saving the relevant data.
- Display can show engine speed, fuel level, oil pressure, servo pressure, wind speed, engine working time, weight of load lifted by crane, working radius, and lifting boom angle; electronic load chart has a real-time inquiry function, providing the convenient and quick inquiry; the complete fault self-diagnosis and inquiry system is provided, thus reducing the equipment fault handling time.
- Slewing area limit device is optional, to improve the safety of the equipment; sensor has a protection against the lightning strike, thus further improving the safety of the equipment.
- The entire machine adopts the closed wiring way, with waterproof / dust-proof protective grade up to IP65 and with longer life applied.
- Sensor has a protection against the lightning strike, providing higher reliability.
- Slewing area limit device is optional, to improve the safety of the equipment.

### 3) Hydraulic System

- Load sensitive control hydraulic system and well-known brand hydraulic components are adopted, including main pump, main valve, joystick and motor reducer, which are efficient, reliable, stable and energy-saving.
- Advanced rotation and micro-movement performance and limit load regulation ensure smooth and stable operation.
- Three-in-one hydraulic oil cooling system is adopted.

### 4) Main and Auxiliary Hoisting Mechanisms

- Main and auxiliary winches are independently driven. The winch drum is directly driven by winch motor through reducer, and can rotate into two directions through the manipulation of winch handle to carry out lifting and lowering actions of the hook.
- Motor reducer of domestic well-known mature brand is adopted for higher reliability and durability;
- The drum design ensures the multi-layer winding is always in order; steel wire of domestic well-known brand is adopted for higher reliability and durability.

#### Main and auxiliary hoisting mechanisms

Rope speed of the outermost working layer	0~120m/min
Wire rope diameter	φ20mm
Length of main / auxiliary wire rope	230m/160m

**5) Luffing Mechanism**

- The winch drum is directly driven by luffing motor through reducer, and can rotate into two directions through the manipulation of luffing handle to carry out lifting and lowering actions of the hook.
- Motor reducer and steel wire of well-known brands are adopted for higher reliability and durability.
- The drum design ensures the multi-layer winding is always in order.

**6) Swing Mechanism**

- The inner toothing swing drive can rotate 360°.
- Motor reducer of well-known brands is adopted for higher reliability and durability;
- Slewing lock: Pull up the locking pin after the completion of operation or during transportation can ensure the superstructure to be locked, which is convenient and reliable.
- Slewing ring: Sing-row ball type slewing ring.
- Slewing Speed: 0~3 rpm.

**7) Cab**

- SANY's newly designed and manufactured fully enclosed cab features with artistic styling and interior decoration. There are large glass windows, short and long distance beam headlight, and rear-view mirror for more open vision. It is equipped with well ventilated air conditioning and MP3 player. The seat, joystick and all control buttons are all ergonomically designed, which provides the operator with a more comfortable working environment.
- Armrest box: Joystick, electric switch, emergency stop button and ignition lock are installed on left and right armrest box and auxiliary controlling box. The armrest box is adjustable with the seat.
- Seat: Suspension, multimode and multistage adjustable seat is adopted, with unloading switch applied.
- Air conditioning provides heating and cooling air with optimized air duct and air outlet.

**8) Counterweight**

- The superposable tray and counterweight blocks, and new guide devices are easy to assembly and disassembly. 3.3m overall width ensures more convenient transport and lower cost.
- Rear counterweight: weight 24t; composition: tray 6t×1, Counterweight block 6t×3;
- Undercarriage counterweight: 1.5t×2 blocks mounted front and after the base.

## UNDERCARRIAGE

**1)**

Each track frames has an independent traveling drive. The traveling motor drives the machine to achieve independent traveling and turning through drive wheel and reducer.

**2) Telescopic Track:**

Track frame can be expanded and retracted through cylinder.

**3) Track tension:**

Track tension can be adjusted by using hydraulic jack to push guide wheel to adjust clearance between shims.

**4) Crawler Shoes:**

High strength alloy steel with higher durability.

## OPERATION DEVICES

### 1) Boom

- Lattice structure; main chord made of high strength structure steel; each section is connected with pins.
- Basic Boom: 6m boom tip and 6m boom base;
- Insert: 3m×1、6m×1、9m×4;
- Boom Length: 12m~57m.

### 2) Fixed Jib

- Lattice structure; main chord made of high strength structure steel; each section is connected with pins.
- Basic Boom: 4.5m boom tip and 4.5m boom base;
- Insert: 4.5m×2;
- Jib Length: 9m~18m;
- Longest boom + longest jib: 42m boom + 18m jib.

### 3) Boom Extension

- Welded structure; It is jointed with boom through pin for auxiliary hook operation.

### 4) Boom Extension

- 75t lifting hook
- 45t lifting hook
- 15t lifting hook
- 9t ball hook

Notes:

The above operation devices are complete configuration. The order contract shall prevail for specific configuration.

## SAFETY DEVICES

### 1) Assembly/operation Mode Change switch

- In assembly mode, over hoisting limiter, boom angle limiter and load moment indicator will be bypassed for the assembly of the crane.
- In operation mode, all safety limit devices will function.

### 2) Emergency Stop

- In case of emergency, the operator can immediately shut down the entire machine by pressing the emergency stop button.

### 3) Emergency Back-up Function

- When main controller crashes, use electrical emergency plug and manipulate the crane to a safe status. Then all the safety protection function will not be working.

### 4) Integrated moment intelligent control system

- Standard configured SANY load moment limiter is free of calibration, ensuring the high safety and efficiency of the equipment construction.
- Integrated moment intelligent control system can automatically detect the load weight, working radius, and lifting boom angle, and compare with the rated load capacity, actual load, working radius, and lifting boom angle. Under normal operation, it can automatically cut the crane action to dangerous direction, and has a black-box function to record the over-load information.
- Composition: display, controller, angle sensing, and load sensor.

### 5) Main and Auxiliary Hoisting Limiter

- Composed of limit switch and hammer etc. on boom tip to prevent over hoisting of hook block. When the lifting hook is raised to a certain height, the limit switch will be activated. The buzzer on the control panel will alarm and the failure indicator will flash. The lifting operation of hook block will be automatically cut off.

### 6) Lowering Limiter of Main and Auxiliary Winch

- Composed of movement trigger device and proximity switches to prevent wire rope from being over-released. When the wire rope is released near the last three loops, limit switch will work. The system will alarm through buzzer, sending alarm information to the display and automatically stop the lowering of winches.

### 7) Function Lock

- If the function locking handle is not at proper position, all control handles will not function. It can prevent misuse and operational accident due to body impact when getting on or off the cab.

### 8) Drum Locking Device

- There are electrically controlled locking devices for main winch, auxiliary winch and luffing winch. The action can be done only after the button is turned to the release position to prevent misuse of handle, thus ensuring the parking safety of winch during idle states.

### 9) Swing Locking Device

- It can lock the machine at the front, back, left and right direction.



**10) Boom Angle Limiter**

- When the boom angle is greater than 80° , buzzer will give an alarm and the boom operation will be cut off. This protection is controlled by load moment limiter and travel switch.
- When boom angle is less than 30° , the system will alarm through buzzer and display alarm information in combined instrument to automatically stop boom lowering movement. This protection is controlled by load moment indication automatically.

**11) Boom Back-stop Device**

Composed of nesting tubing and spring. It buffers the energy of boom backwards tilting by spring force to prevent the boom from tilting backwards.

**12) Boom Angle Indicator**

The angle indicator device is fixed on the boom base near the cab for convenient view of operator.

**13) Hook Latch**

There are baffle on the hook to prevent the wire rope fall off.

**14) Monitoring System**

Remote monitoring system is equipped for GPS positioning, GPRS data transfer, machine use inquiries, running data monitoring and analysis and remote fault diagnosis.

**15) Lightning Protection Device**

The lightning protection device combines a base (ground) device to effectively prevent damage to operator in the case of a lightning strike.

**16) Three-color Load Alarm Light**

Red, Yellow and Green lights indicate loading situations in Real-Time. If the actual load is less than 90% of the rated load, the Green light will turn on. If the actual load is more than 90%, but less than 100% of the rated load, the Yellow light will turn on with intermittent sound alarm. If the actual load is 100% of the rated load, the Red light will turn on with continuous sound alarm. If the actual load is 100%of the rated load, then the system will immediately cease the operation of the crane.

**17) Audio and Visual Alarm**

When the engine works, the light will flash; when at traveling or slewing operation state, the sound alarm will be given.

**18) Slewing Alarm**

When the machine is traveling or slewing, the slewing lamp will flash.

**19) Illumination Light**

The short-beam lamp at the front of cab, front angle adjustable far-beam lamp, cab lamp and other lighting device at night are equipped to improve the visibility of construction.

**20) Rearview Mirror**

Rearview mirrors are equipped on the right side of cab and handrail of front hood to facilitate the monitoring of the back of the crane.

**21) Pharos**

It is on the top of boom for altitude lightning.

**22) Anemometer**

It is on the top of boom to monitor the wind speed in real time and to transfer data to the display in cab.

# SCC750E

04	Outline Dimension
05	Main Technical Features
06	Performance Data
07	Transport Dimensions
10	Hoisting Diagram



## OPERATING CONDITION COMBINATION

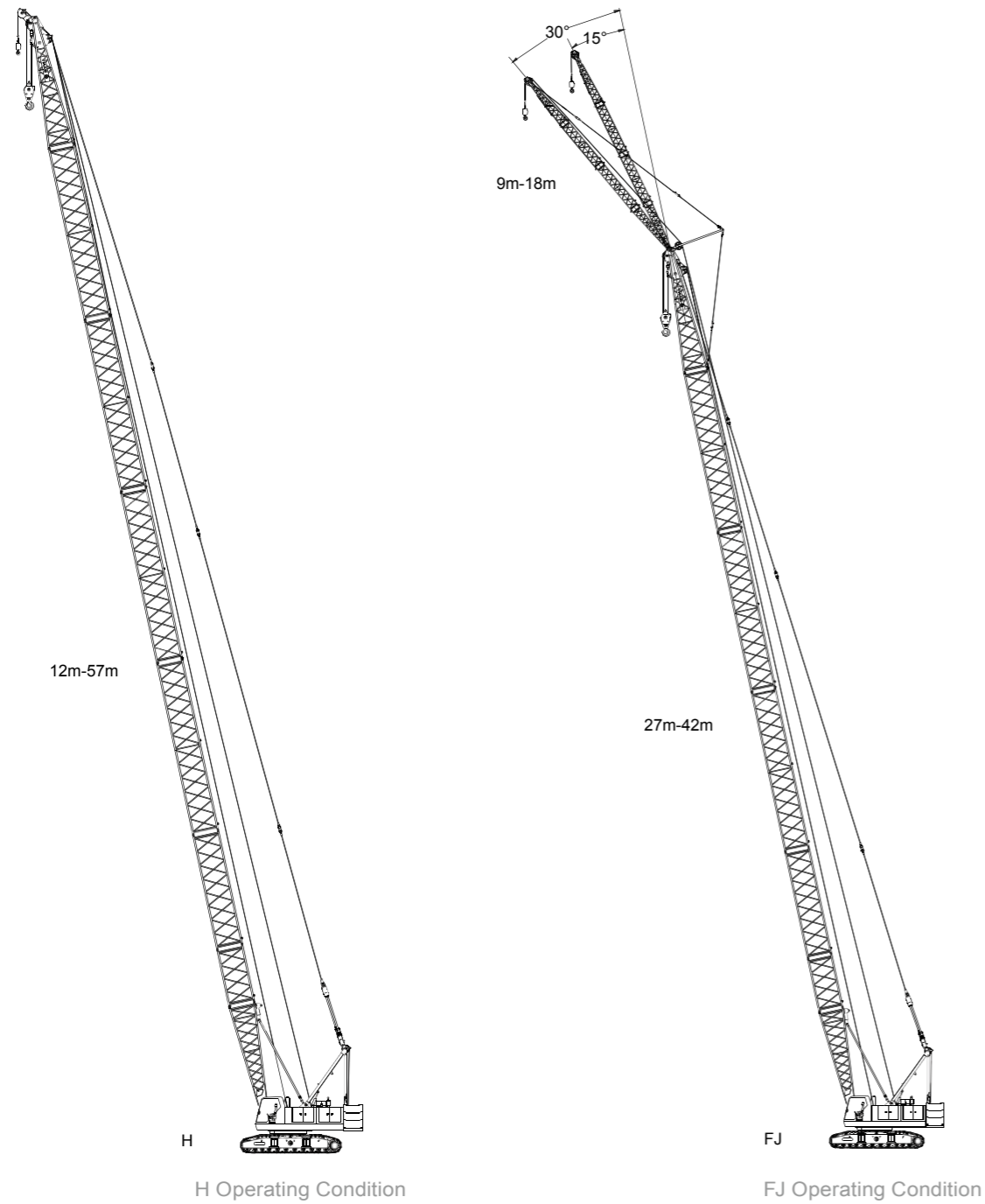

## H OPERATING CONDITION COMBINATION

Boom length	Insert		
	3m	6m	9m
12	-	-	-
15	1	-	-
18	-	1	-
21	-	-	1
24	1	-	1
27	-	1	1
30	1	1	1
33	1	-	2
36	-	1	2
39	1	1	2
42	-	-	3
45	1	-	3
48	-	1	3
51	1	1	3
54	-	-	4
57	1	-	4
57	1	1	4

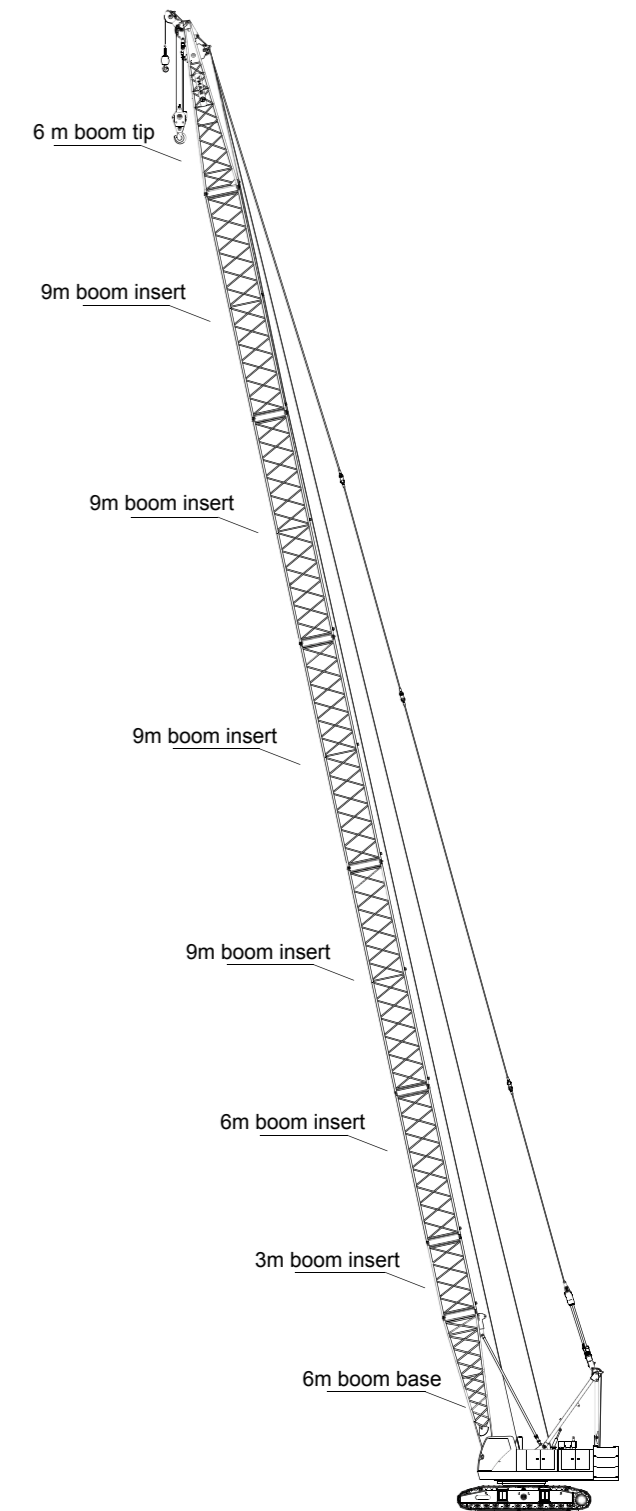

## OPERATING RANGE DIAGRAM OF H OPERATING CONDITION

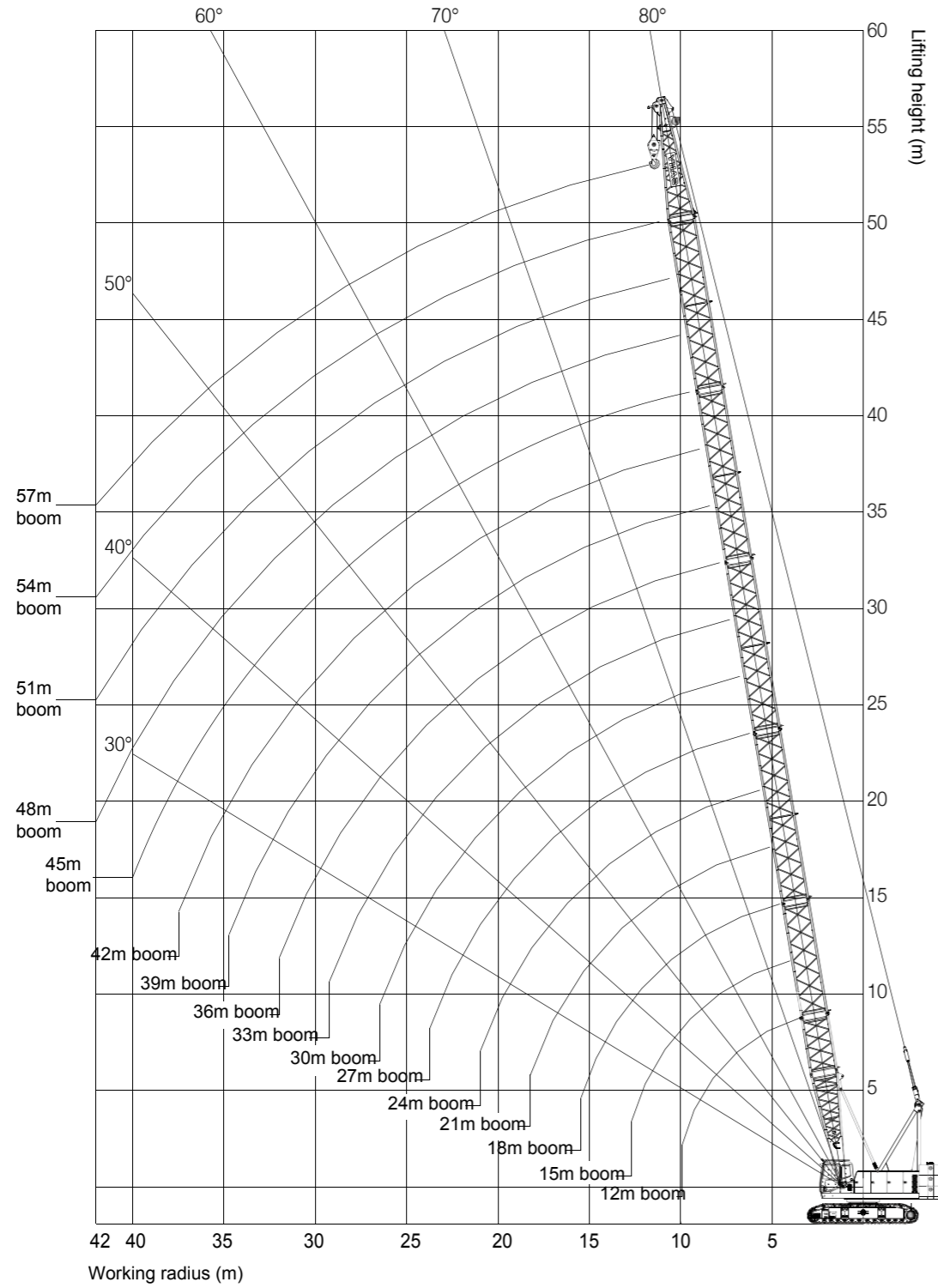

## BOOM LOAD CHART (H OPERATING CONDITION)

Boom Load Chart(H Operating Condition)

Radius	Boom Length 12m~33m Rear Counterweight 24t								Radius	
	12	15	18	21	24	27	30	33		
3.6	75									3.6
4	71	71								4
5	56	56	56	53.9						5
6	43	42.6	42.3	42	41.6					6
7	34.1	33.9	33.7	33.5	33.2	32.9	32.6			7
8	28.2	28	27.9	27.7	27.5	27.3	27	26.8		8
9	24	23.8	23.7	23.6	23.4	23.2	23	22.8		9
10	20.8	20.7	20.6	20.5	20.3	20.1	19.9	19.8		10
11	18.4	18.2	18.1	18	17.9	17.7	17.5	17.4		11
12		16.2	16.2	16.1	15.9	15.8	15.6	15.5		12
13		14.6	14.6	14.5	14.3	14.2	14	13.9		13
14		13.3	13.2	13.1	13	12.9	12.7	12.6		14
15			12.1	12	11.8	11.7	11.6	11.5		15
16			11.1	11	10.9	10.8	10.6	10.5		16
18				9.4	9.3	9.2	9	8.9		18
20					8	8	7.8	7.7		20
22					7.1	7	6.8	6.7		22
24						6.1	6	5.9		24
26							5.3	5.2		26
28								4.6		28

# BOOM LOAD CHART (H OPERATING CONDITION)

## Boom Load Chart(H Operating Condition)

Radius	Boom Length 36m~57m Rear Counterweight 24t								Radius
	36	39	42	45	48	51	54	57	
8	26.6								8
9	22.6	22.4	22.1						9
10	19.6	19.4	19.3	19.1	18.6				10
11	17.3	17.1	16.9	16.8	16.6	16.2	15.8		11
12	15.4	15.2	15	14.9	14.7	14.6	14.3	13.9	12
13	13.8	13.6	13.5	13.3	13.2	13	12.9	12.6	13
14	12.5	12.3	12.2	12	11.9	11.7	11.6	11.4	14
15	11.4	11.2	11.1	10.9	10.8	10.6	10.5	10.3	15
16	10.4	10.2	10.1	10	9.8	9.7	9.6	9.4	16
18	8.8	8.7	8.5	8.4	8.3	8.1	8	7.9	18
20	7.6	7.4	7.3	7.2	7.1	6.9	6.8	6.6	20
22	6.6	6.5	6.3	6.2	6.1	6	5.8	5.7	22
24	5.8	5.7	5.5	5.4	5.3	5.2	5	4.9	24
26	5.1	5	4.9	4.8	4.6	4.5	4.4	4.3	26
28	4.6	4.4	4.3	4.2	4	3.9	3.8	3.7	28
30	4.1	3.9	3.8	3.7	3.5	3.4	3.3	3.2	30
32	3.6	3.5	3.4	3.3	3.1	3	2.9	2.8	32
34		3.1	3	2.9	2.7	2.6	2.5	2.3	34
36			2.7	2.6	2.4	2.3	2.2	2	36
38				2.3	2.1	2	1.8	1.7	38
40					2	1.8	1.7	1.6	40
42						1.6	1.5	1.3	42

**Notes-Rated Load of Crane**

- The rated load in the table is the value under the condition that the non-traveling heavy load is lifted slowly and steadily from the solid and flat ground.
- The rated load in the table is calculated based on 75% of the tipping load under wind speed of less than 9.8m/s.
- The rated load value in the table includes the weight of lifting hooks. The actual hoisting capacity is value that the rated value minus the weight of all lifting tools (including 75t hooks 0.70t, 45t lifting hook 0.49t, 15t lifting hook 0.28t, 9t lifting hook 0.25t).
- With jib or tip extension installed, the rated load value in the table includes the weight of main and auxiliary lifting hooks, and the values listed in table below. The actual hoisting capacity of the crane is a value that the value in the boom rated load chart minus the weight listed in the table below and boom head equivalent weight converted by the weight of main hook, auxiliary hook, and wire rope.

Jib length (m)	9	13.5	18	Jib extension
Deducted weight (t)	1.2	1.5	1.8	0.3

- The length of installable boom is 27m~42m.
- The track frame shall be expanded during lifting.
- All values in load chart are applicable for 360° rotation.

# FIXED JIB OPERATING CONDITION

Jib Length	Insert
m	4.5m
9	-
13.5	1
18	2

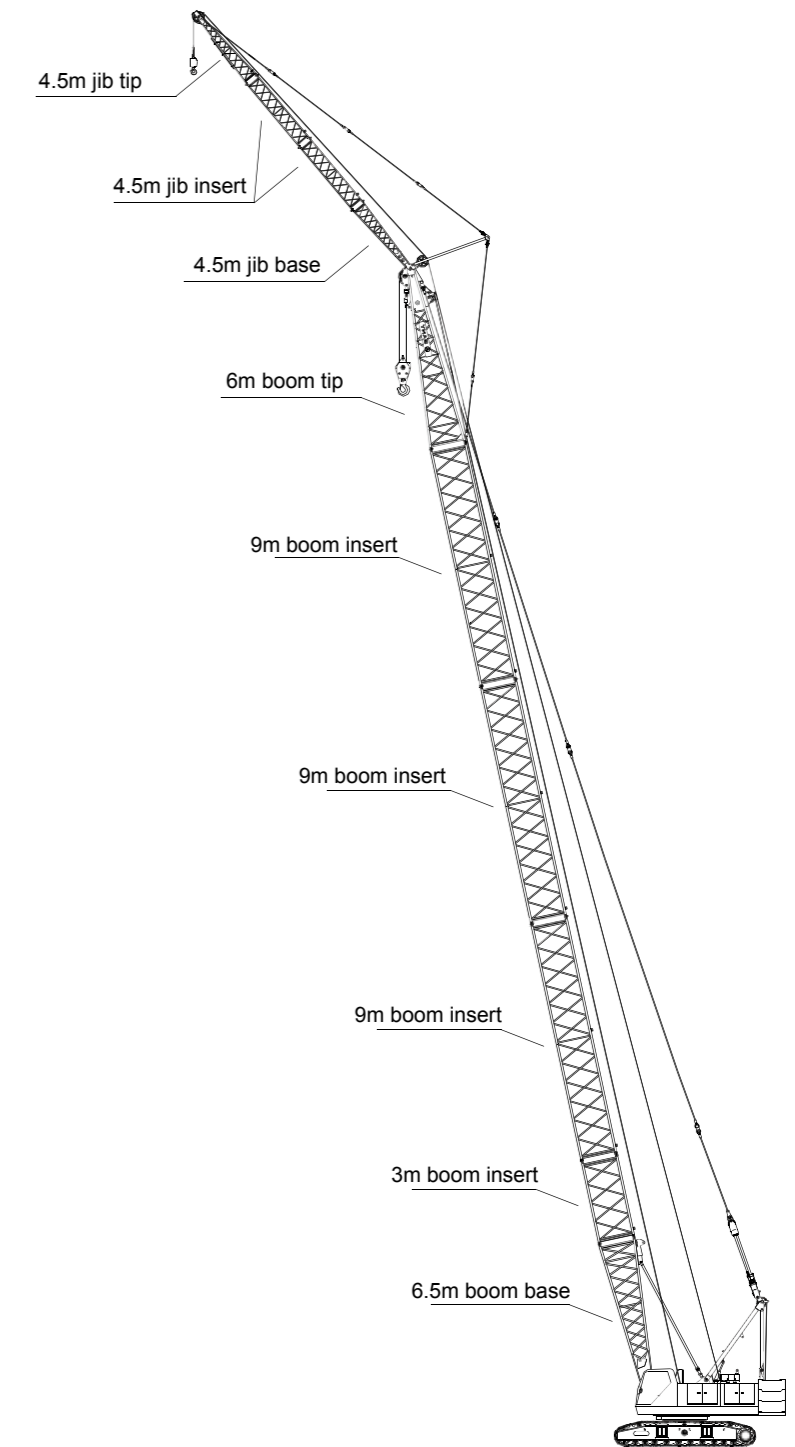

## OPERATING RANGE OF FIXED JIB OPERATING CONDITION

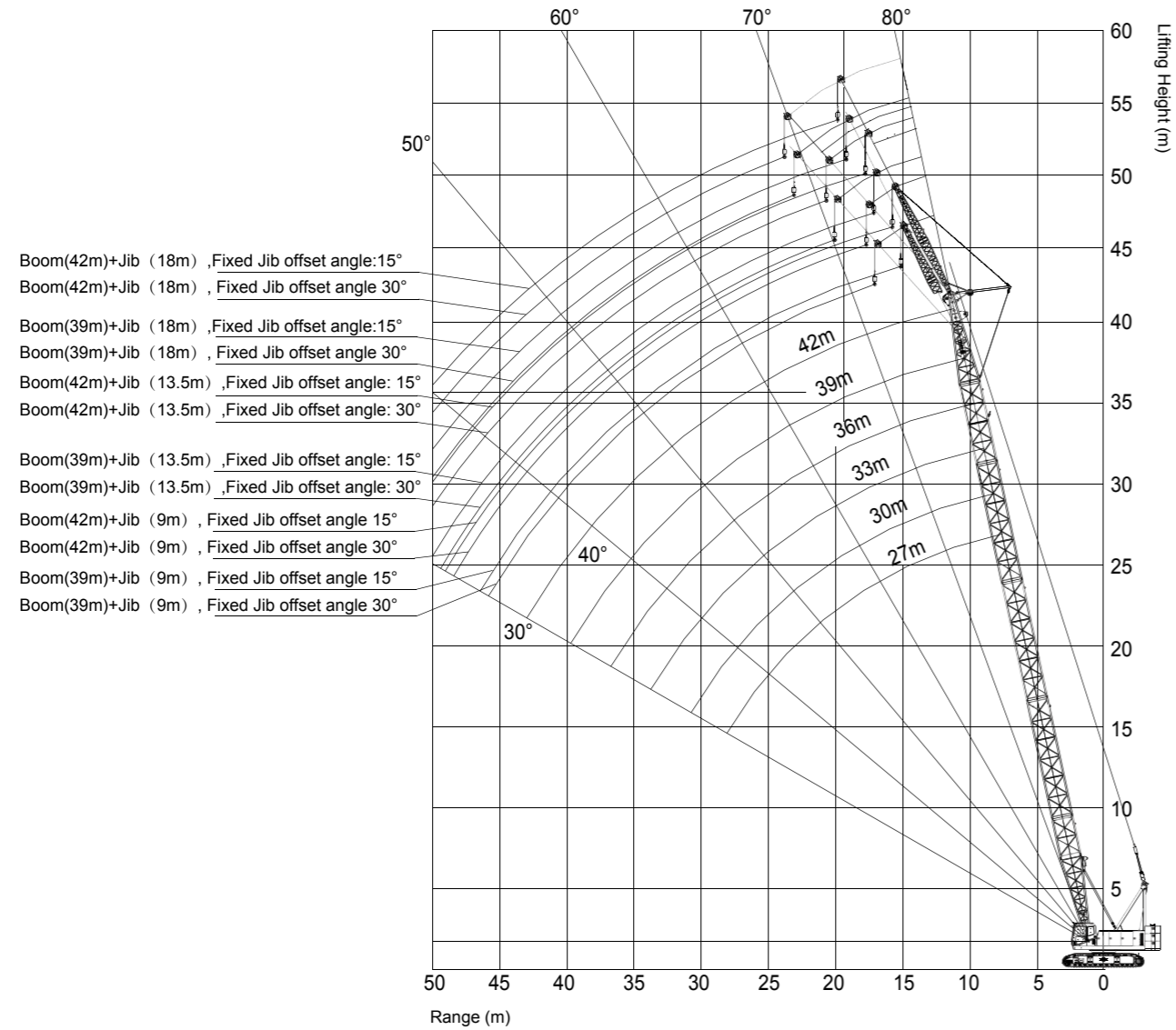

## FIXED JIB LOAD CHART (FJOPERATING CONDITION)

SCC750E Fixed Jib Load Chart 1/3  
( Boom 27m-30m, Jib 9m-18m)

Radius	Counterweight 24t												Radius
	27						30						
	9		13.5		18		9		13.5		18		
10	7/ 10.2						7/ 10.8						10
12	7.0	7/ 12.2	7/ 12.2				7.0	7/ 12.7	7/ 12.7				12
14	7.0	7.0	7.0	6.3/ 15.1	5.4/ 14.1		7.0	7.0	7.0	6.3/ 15.7	5.4/ 14.7		14
16	7.0	7.0	7.0	6.1	5.3		7.0	7.0	7.0	6.2	5.3		16
18	7.0	7.0	7.0	5.8	5.2	4.8/ 18.1	7.0	7.0	7.0	5.9	5.2	4.8/ 18.6	18
20	7.0	7.0	6.7	5.4	5.1	4.5	7.0	7.0	7.0	5.6	5.1	4.6	20
22	6.6	6.7	6.3	5.2	5.0	4.3	6.5	6.7	6.5	5.3	5.0	4.4	22
24	5.8	5.9	5.8	4.9	4.9	4.1	5.8	5.9	5.8	5.0	5.0	4.2	24
26	5.2	5.3	5.3	4.7	4.6	3.9	5.1	5.2	5.2	4.8	4.8	4.0	26
28	4.6	4.7	4.7	4.5	4.3	3.7	4.5	4.6	4.6	4.6	4.5	3.8	28
30	4.2	4.2	4.2	4.3	4.1	3.5	4.1	4.1	4.2	4.3	4.2	3.6	30
32	3.8	3.8	3.8	3.9	3.9	3.4	3.7	3.7	3.7	3.8	3.8	3.5	32
34	3.5/ 33.2	3.5/ 33.5	3.5	3.5	3.5	3.3	3.3	3.3	3.4	3.5	3.4	3.4	34
36			3.1	3.2	3.2	3.2	3/ 35.8	3.0	3.1	3.1	3.1	3.2	36
38			2.9/ 37.5	2.9/ 38	2.9	3.0		3/ 36.1	2.7	2.8	2.8	2.9	38
40					2.6	2.7			2.5	2.5	2.5	2.6	40
42					2.4/ 41.9	2.4			2.5/ 40.1	2.4/ 40.6	2.3	2.3	42
44						2.3/ 42.5					2.0	2.1	44
46											2/ 44.5	2/ 45.1	46

## FIXED JIB LOAD CHART (FJOPERATING CONDITION)

**SCC750E Fixed Jib Load Chart 2/3**  
(Boom 33m-36m, Jib 9m-18m)

Counterweight 24t													
Radius	33						36						Radius
	9		13.5		18		9		13.5		18		
	15	30	15	30	15	30	15	30	15	30	15	30	
10	7/ 11.3						7/ 11.9						10
12	7.0	7/ 13.3	7/ 13.3				7.0	7/ 13.9	7/ 13.9				12
14	7.0	7.0	7.0			5.4/ 15.3	7.0	7.0	7.0			5.4/ 15.9	14
16	7.0	7.0	7.0	6.3/ 16.3	5.3		7.0	7.0	7.0	6.3/ 16.8	5.4		16
18	7.0	7.0	7.0	6.0	5.2	4.8/ 19.2	7.0	7.0	7.0	6.1	5.3	4.8/ 19.8	18
20	7.0	7.0	7.0	5.7	5.2	4.7	7.0	7.0	7.0	5.8	5.2	4.8	20
22	6.4	6.6	6.5	5.4	5.1	4.5	6.3	6.5	6.4	5.5	5.1	4.6	22
24	5.6	5.8	5.7	5.2	5.0	4.3	5.5	5.7	5.6	5.3	5.0	4.3	24
26	5.0	5.1	5.1	5.0	4.9	4.1	4.9	5.0	5.0	5.1	5.0	4.2	26
28	4.4	4.5	4.5	4.7	4.6	3.9	4.3	4.4	4.4	4.6	4.5	4.0	28
30	4.0	4.0	4.0	4.2	4.1	3.7	3.8	3.9	3.9	4.1	4.0	3.8	30
32	3.5	3.6	3.6	3.7	3.7	3.6	3.4	3.5	3.5	3.6	3.6	3.7	32
34	3.2	3.2	3.3	3.4	3.3	3.5	3.0	3.1	3.1	3.3	3.2	3.4	34
36	2.8	2.9	2.9	3.0	3.0	3.1	2.7	2.8	2.8	2.9	2.9	3.0	36
38	2.5	2.6	2.6	2.7	2.7	2.8	2.4	2.4	2.5	2.6	2.5	2.7	38
40	2.5/ 38.4	2.5/ 38.7	2.3	2.4	2.4	2.5	2.1	2.2	2.2	2.3	2.3	2.4	40
42			2.1	2.1	2.1	2.2	2/ 41	2/ 41.3	1.9	2.0	2.0	2.1	42
44			2/ 42.7	2/ 43.2	1.9	2.0			1.7	1.8	1.8	1.9	44
46					1.7	1.7			1.6/ 45.3	1.6/ 45.8	1.6	1.6	46
48					1.6/ 47.1	1.6/ 47.7					1.4	1.4	48
50											1.2/ 49.7	1.2	50

## FIXED JIB LOAD CHART (FJOPERATING CONDITION)

**SCC750E Fixed Jib Load Chart 3/3**  
(Boom 39m-42m, Jib 9m-18m)

Counterweight 24t													
Radius	39						42						Radius
	9		13.5		18		9		13.5		18		
	15	30	15	30	15	30	15	30	15	30	15	30	
12	7/ 12.5						7/ 13.1						12
14	7.0	7/ 14.4	7/ 14.5				7.0	7/ 15	7/ 15				14
16	7.0	7.0	7.0	6.3/ 17.4	5.4/ 16.4		7.0	7.0	7.0	6.3/ 18	5.4/ 17		16
18	7.0	7.0	7.0	6.2	5.3		7.0	7.0	7.0	6.3	5.3		18
20	7.0	7.0	7.0	5.9	5.2	4.8/ 20.4	7.0	7.0	7.0	6.0	5.2	4.8/ 20.9	20
22	6.2	6.4	6.3	5.6	5.1	4.6	6.1	6.3	6.2	5.7	5.2	4.7	22
24	5.4	5.6	5.5	5.4	5.1	4.4	5.3	5.5	5.4	5.5	5.1	4.5	24
26	4.8	4.9	4.9	5.1	4.9	4.2	4.6	4.8	4.7	5.0	4.8	4.3	26
28	4.2	4.3	4.3	4.5	4.4	4.1	4.1	4.2	4.2	4.4	4.3	4.1	28
30	3.7	3.8	3.8	4.0	3.9	3.9	3.6	3.7	3.7	3.9	3.8	4.0	30
32	3.3	3.4	3.4	3.6	3.5	3.7	3.2	3.3	3.3	3.5	3.4	3.6	32
34	2.9	3.0	3.0	3.2	3.1	3.3	2.8	2.9	2.9	3.1	3.0	3.2	34
36	2.6	2.7	2.7	2.8	2.7	2.9	2.4	2.5	2.5	2.7	2.6	2.8	36
38	2.3	2.3	2.4	2.5	2.7	2.6	2.1	2.2	2.2	2.4	2.3	2.5	38
40	2.0	2.1	2.1	2.2	2.7	2.3	1.9	1.9	2.0	2.1	2.0	2.2	40
42	1.8	1.8	1.8	1.9	2.7	2.0	1.6	1.7	1.7	1.8	1.8	1.9	42
44	1.6/ 43.6	1.6/ 43.9	1.6	1.7	2.7	1.8	1.4	1.4	1.5	1.6	1.5	1.7	44
46			1.4	1.5	2.7	1.6	1.2	1.2	1.3	1.3	1.3	1.4	46
48			1.2/ 47.9	1.2	2.7	1.3	1.2/ 46.2	1.2/ 46.5	1.1	1.1	1.1	1.2	48
50				1.2/ 48.4	2.7	1.1			0.9	0.9	1.0	1.0	50



## Quality Changes the World

### **SANY GROUP CO., LTD.**

Address: SANY Industrial Park, Economic and Technological  
Development Zone, Changsha, Hunan, China

Service Hotline: +0086-4006-098-318

E-mail: [crd@sany.com.cn](mailto:crd@sany.com.cn)

For more information, please visit: [www.sanygroup.com](http://www.sanygroup.com)

